



# CB Series BATTERY CHARGING EQUIPMENT

Uninterruptible direct current power supply system. Equipment consisting of a charger and a battery, housed in an IP22 metal cabinet with lockable door, which provides DC output voltage, both in the presence and absence of mains power.



## Possibilities of the standard range

output voltage (Vdc)	caliber (A)	capacity (Ah)
12 - 24 - 48 - 110 - 120	1 - 3 - 6 - 10	4 - 7 - 14

It is possible to request other output voltages and battery capacities: the range of CB equipment is very wide and totally customizable.

- ◇ The charger can simultaneously supply the charging intensity of the battery and the one required for the use of the recharge, up to the value of its total size.
- ◇ The battery can be either Ni-Cd (HT) or Pb, in both cases watertight, maintenance-free and without gas evolution.

## Signalling and alarms

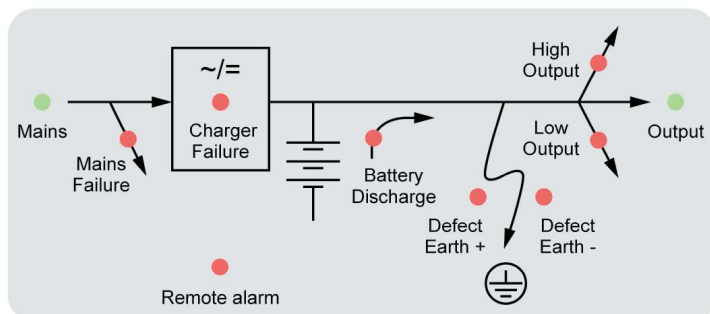

- ◇ It incorporates a synoptical label with LED diodes located on the door, with multiple status signals and alarms.
- ◇ The remote alarm is turned on after a time delay of 10-20 seconds since any alarm occurs. A potential-free inverter contact allows this alarm to be transmitted remotely.